

# FICHE D'HOMOLOGATION HOMOLOGATION FORM



## COMMISSION INTERNATIONALE DE KARTING – FIA



### CARENAGE AVANT / FRONT FAIRING

Constructeur	<i>Manufacturer</i>	COMER S.p.A.
Marque	<i>Make</i>	TOP KART
Modèle	<i>Model</i>	AIR
Catégorie	<i>Category</i>	Toutes / All
Durée de l'homologation	<i>Validity of the homologation</i>	6 ans / years
Nombre de pages	<i>Number of pages</i>	3

La présente Fiche d'Homologation reproduit descriptions, illustrations et dimensions au moment de l'homologation CIK-FIA.

*This Homologation Form reproduces descriptions, illustrations and dimensions at the moment of the CIK-FIA homologation.*



PHOTOS VUE DE DEVANT, DE DESSUS ET DE COTÉ, DU CARENAGE AVANT AVEC SUPPORTS

*PHOTO FROM FRONT, ABOVE AND SIDE OF FRONT FAIRING WITH SUPPORTS*

Signature et tampon de l'ASN  
*Signature and stamp of the ASN*

Signature et tampon de la CIK-FIA  
*Signature and stamp of the CIK-FIA*



*Grasso*



*[Signature]*

**CARÉNAGE AVANT AVEC SUPPORTS**

Dessin technique (dimensions d'encombrement – matériau, diamètre et épaisseur des tubes supports)

**FRONT FAIRING WITH SUPPORTS**

Technical drawing (fairing main external dimensions – supports material, diameter and wall thickness)

Masse en g (seule)

Mass in g only)

**1500 g**

+/-10 %

Masse en g (avec supports )

Mass in g ( support only)

**2700 g**

+/-5 %

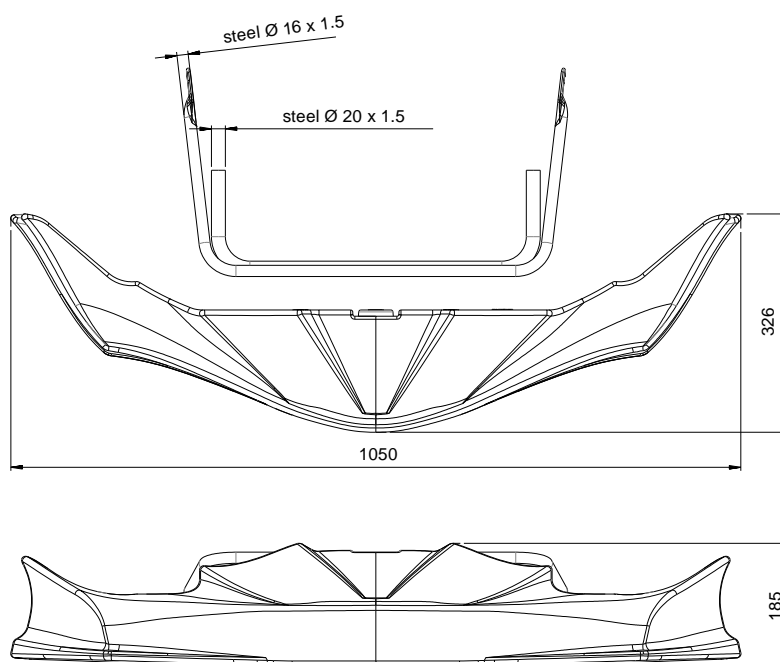

PHOTO (complet avec supports) / (complete with supports)



**FIXATION CARÉNAGE AVANT**

Dessin technique éclaté

**FRONT FAIRING ATTACHMENT***Exploded technical drawing*

PHOTO DU MARQUAGE DU NUMERO  
D'HOMOLOGATION (et du logo CIK-FIA sur les  
éléments plastiques)

*PHOTO OF THE HOMOLOGATION NUMBER  
MARKING (and of the CIK-FIA logo on the  
plastic parts)*

**Le marquage doit rester clairement visible en permanence**  
***The marking must be clearly visible at all times***

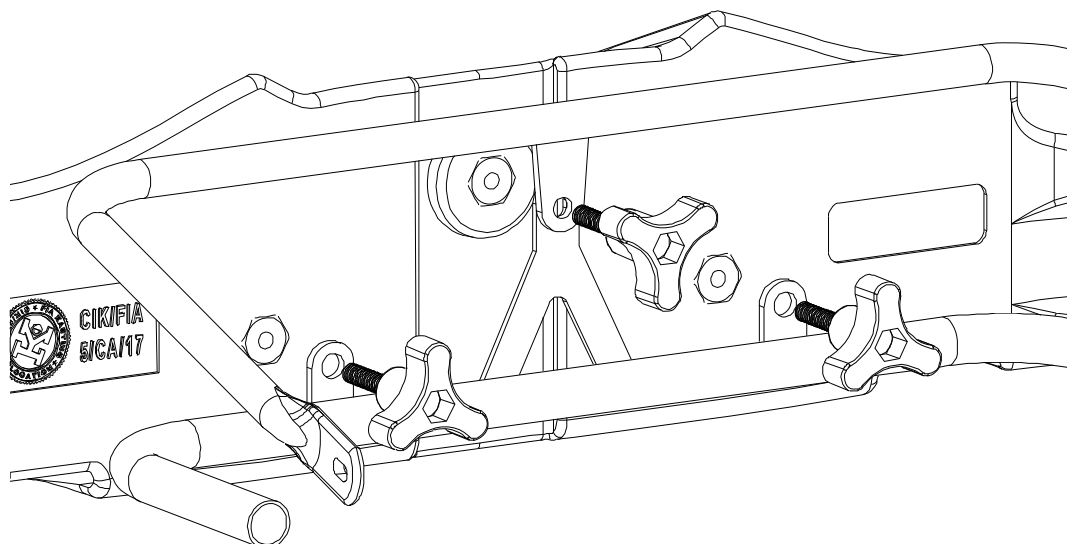